

18X11 SPINDLE INITIATOR FOR SCHLAFHORTS WINDING MACHINE

**5mm
SHIELDED**

OPERATIONAL DATA:

1. MOUNTING IN METAL	SHIELDED
2. SENSING DISTANCE	5mm
with Fe-ST37 PLATE SIZE	
18mm X 18mm X 1 mm	
3. HYSTERESIS	3% TO 15%
4. REPEATABILITY	0.01mm
5. TEMPRATURE DRIFT	<10%
6. AMB. TEMP. RANGE	0 DEG.C. TO 70 DEG.C.

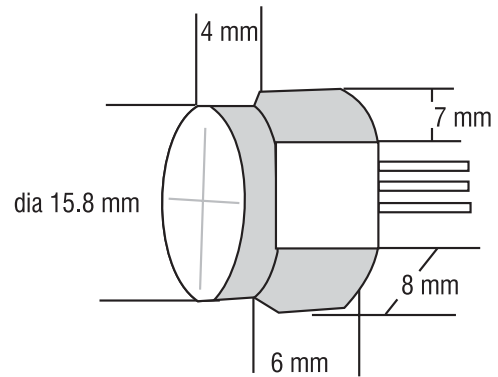

ELECTRICAL DATA:

7. OPERATING VOLTAGE	10V30V DC
8. CURRENT CONSUMPTION	<20mA
9. DROPOUT VOLTAGE	<1V @ max load current
10. SWITCHING FREQUENCY	1 KHz
11. LOAD CURRENT (MAXIMUM)	100 mA

ORDERING CODE Eqv. to SCHLAFHORTS PART NO:

PSICY18NDNOCL05RS	8.85910017 #
	8.85910033 #
	8.85910034 #
	8.85910035 #
	8.85910055 #

MECHANICAL DATA:

12. HOUSING	ABS ENCLOSURE Dia 18mm X 10mm
13. MOUNTING	WITH CLAMP FOR FLUSH MOUNTING IN 4mm THICK METALLIC WALL
14. TERMINATION	Cu PVC INSULATED WIRELEADS 3 X 0.34 Sq. mm LENGTH=0.5m

PROTECTION FEATURES:

15. ENVIRONMENTAL	IP67
16. POLARITY REVERSAL	YES

CONNECTION DETAILS:

BROWN	+V
BLACK	OUTPUT
BLUE	OV



Recommended for the application subject to manufacturer`s change time to time.

**Please contact factory for different barrel lengths.

Specifications are subject to change without notice.

